

6" Touchscreen Camera Monitor

USB2.0 Recording | HDMI with LUT Loop-out

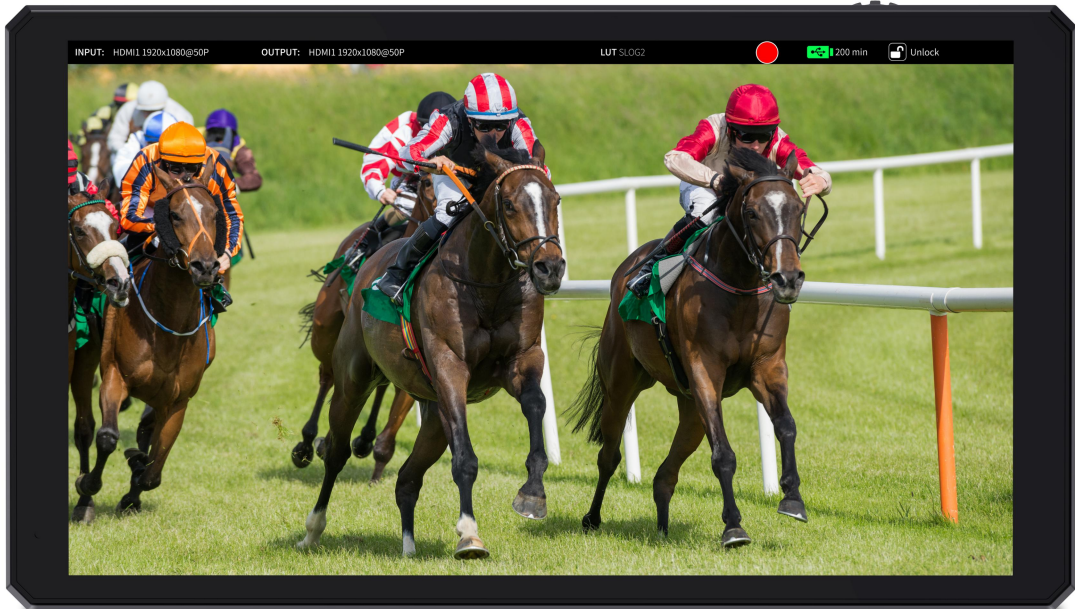

User Manual

Foreword

Thank you for purchasing our 6-inch Full HD touch screen monitor. Please read this manual carefully before using the unit. Have a great experience!

CAUTION

1. Please avoid the heavy impact and drop onto the ground when move the product.
2. The screen of this product is made of glass.Keep away from injury if the screen is broken.
3. Keep the product away from the heat source, and avoid the prolonged exposures to the sun as the LCD screen will be damaged.
4. Please do NOT use chemical solutions to clean this product. Please wipe the monitor with a clean soft cloth to maintain the brightness of the surface.
5. No adjustable components are in the monitor. Please do not take apart or repair the unit by yourself, to avoid the damage of the product.

Key Features

- 6-inch 1920x1080 full HD IPS screen
- Touch screen menu operation, improve shooting efficiency
- New menu interface, more intuitive and intelligent
- HDMI 2.0 input supports up to 4K@60Hz, 3G-SDI (optional)
- HDMI supports LUT loop-out
- Support HDR monitoring, what you see is what you get
- Support 3D LUT Log to REC.709 and user 3D LUT upload

- With Waveform, Histogram, False Color, Monochrome etc. functions, can help you accurately exposure and focus every shot.
- Stereo Earphone output
- DC 8.4V power out to power your DSLR camera or mirrorless camera
- Built-in cooler (low, medium, high) to adjust
- Flexible power supply (DC IN 12V, F970 battery plate for F970 batteries)

CONTENTS

1. Product Description	4
1.1 Front + Rear	4
1.2 Button / Interface Instruction	4
1.3 Power Supply Way	6
1.4 Mount Points	7
2. Menu Operation Instruction	8
2.1 Touch Screen Menu Operation	8
2.2 MENU Wheel Menu Operation	9
3. Function Instruction	9
3.1 Menu Function	9
3.2 Shortcut Menu	14
3.3 Status column	14
4. Support Formats	16
5. Technical Parameters	16
6. Trouble Shooting	17

1. Product Description

1.1 Front + Rear

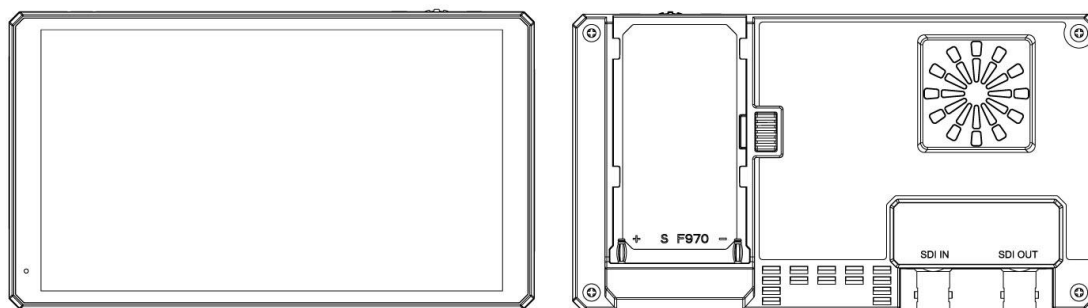

1.2 Button / Interface Instruction

● Top

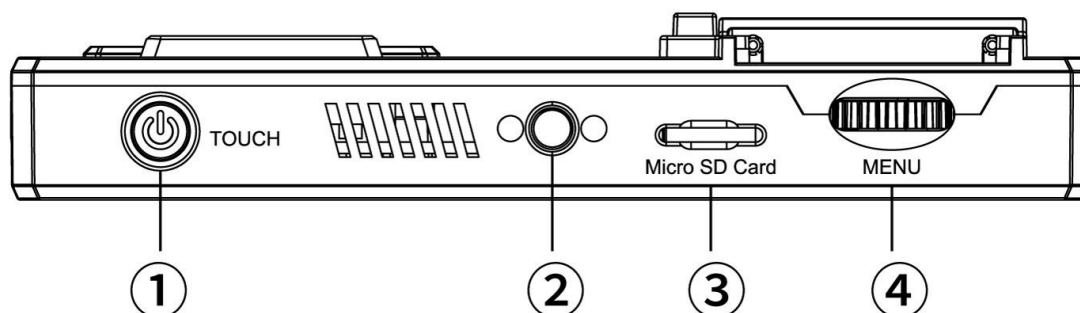

①	Power/Touch Function Button	Long press to turn on/off power; short press to turn on/off the screen touch function
②	1/4 Screw Thread	Use for mount on the bracket, etc.
③	Micro SD Card Slot	Use for upgrade/ LUT files import
④	MENU Wheel Button	See details 2.2 MENU Wheel Menu Operation in 2. Menu Operation Instruction.

● Bottom

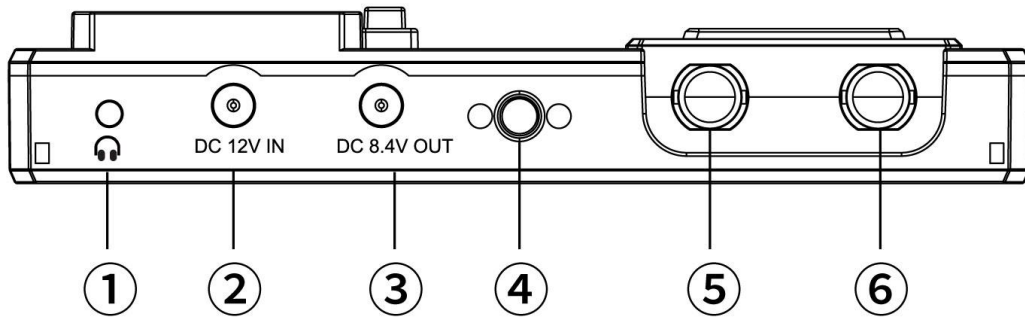

①	Audio Output Interface	3.5mm Analog audio
②	Power Input Interface	DC 12V/1.5A
③	Power Output Interface	DC 8.4V/2A
④	1/4 Screw Thread	Use for mount on the bracket, etc.
⑤	SDI Signal Input Interface	Optional
⑥	SDI Signal Output Interface	Optional

● **Left**

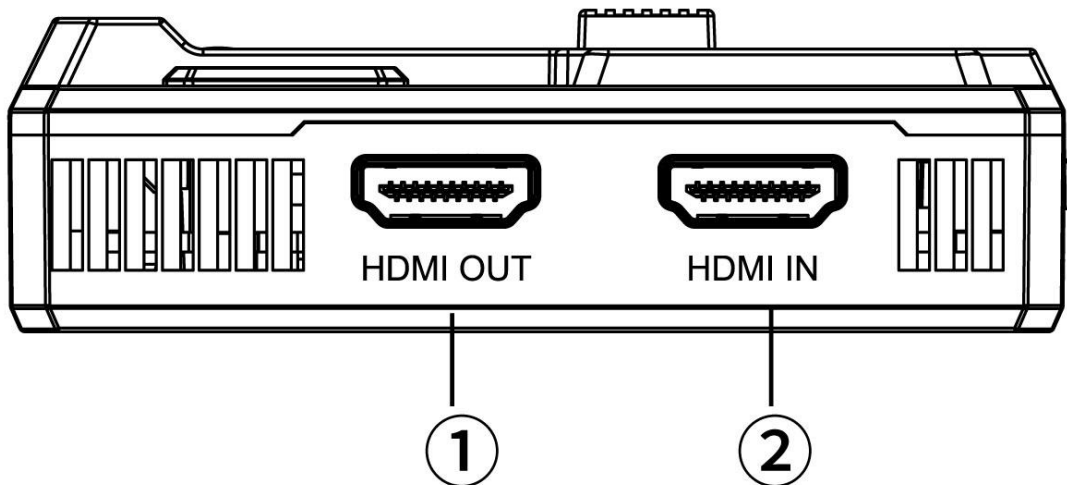

①	HDMI Signal Output Interface	HDMI 1.4
②	HDMI Signal Input Interface	HDMI 2.0

● **Right**

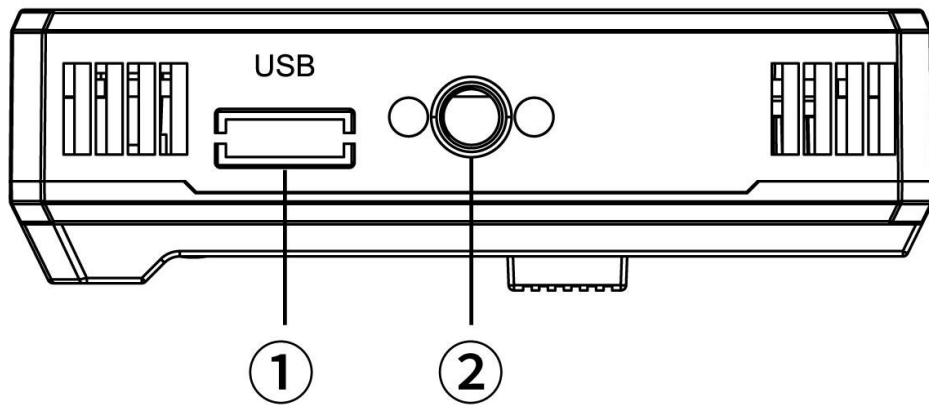

①	USB2.0 Interface	Recording
②	1/4 Screw Thread	Use for mount on the bracket, etc.

1.3 Power Supply Way

(1) The rear cover of the monitor is equipped with F970 battery plate, which is applicable to F970 series of batteries.

Sony F970 battery plate for battery of Sony DV:

Sony F970 F960 F950 F930 F770 F750 F730 F570 F550 F530 series

Remark: It is recommended to use standard original F970 batteries. Different specifications of the battery have different capability. The working time for the monitor will be different. Higher capability (working time) will be longer. Please take off the battery from the monitor if you don't use the monitor in a long time.

(2) **DC IN 12V:** DC power input, polarity as the input power , Barrel (5.5mm outer, 2.1mm inner) at the bottom of the monitor, DC 7~14V Input.

(3) **DC OUT 8.4V:** DC power output interface, polarity as the output power 



Barrel output for powering your camera with a separately available DC coupler via adaptor (NP-FW50 Sony & LP-E6 Canon&DMW-BLF19 Panasonic). More adapters coming soon.

1.4 Mount Points

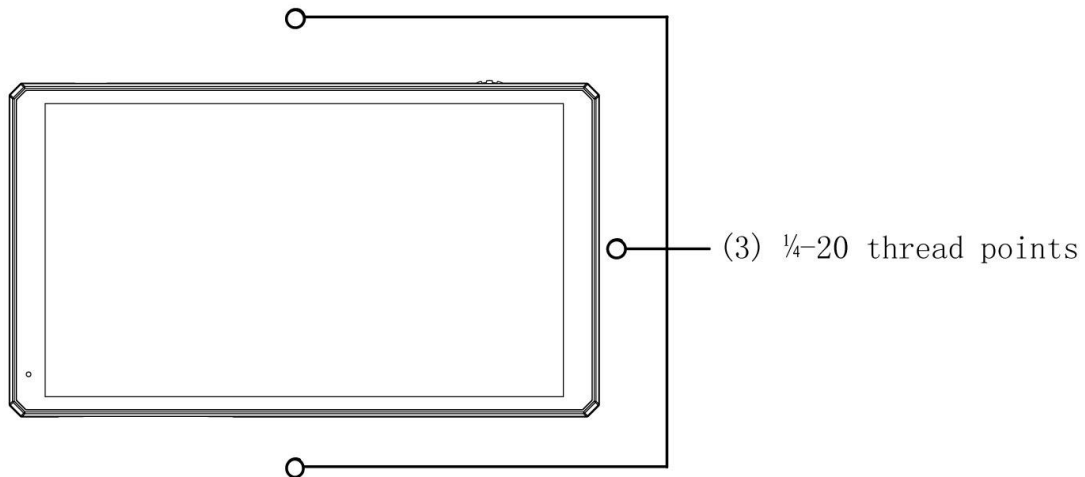
There are (3) 1/4-20 thread points (top, bottom, right) can be easily connected to the hot shoe mount, tripod fixed installation.



2. Menu Operation Instruction

After the monitor is properly connected to the power supply, the  button display (red indicating). Long press  button to turn on the monitor and turns green indicating.

After startup, short press  button to select to turn the screen touch function on or off.

2.1 Touch Screen Menu Operation (turn on the screen touch function)

- ①. Double-click on the screen to open the main menu (show on the left side of the screen) and click on the corresponding menu to display the secondary menu. You can enter the corresponding function option and click directly to select or set. Click the touch screen to exit the menu.
- ②. When the menu is not displayed, swipe up from the bottom of the screen to open the shortcut menu, and click on the corresponding menu box to open or set the corresponding function.
- ③. When the menu is not displayed, on the left side of the screen (1/2 split screen), you can directly adjust the brightness of the screen backlight; on the right side of the screen (1/2 split screen), you can directly adjust the volume.

Figure:

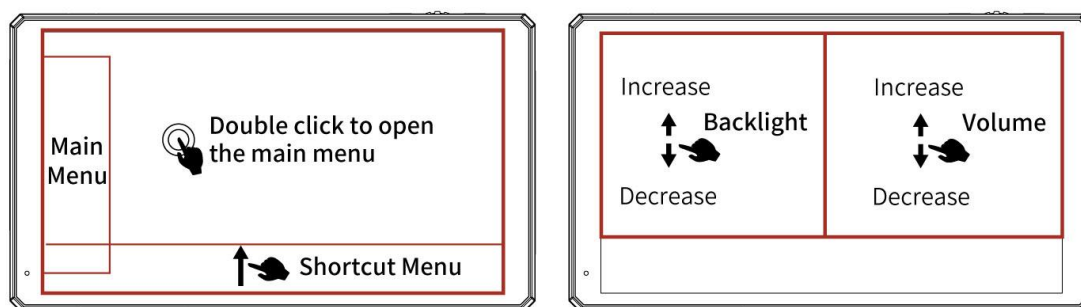

2.2 MENU Wheel Menu Operation

- ①. When the menu is not displayed, directly rotate the wheel to backlight or volume adjustment. The wheel option can be set to backlight or volume in the menu  System.
- ②. Short press the MENU wheel to open the main menu (on the left side of the screen). Rotate the wheel to select the secondary function menu. After selecting it, press the wheel, then rotate the wheel to select or set the option function.
- ③. Long press the MENU wheel to open the shortcut menu (below the screen), rotate the wheel to select the shortcut menu option, press the wheel to directly turn on/off the function, if you press the parameter selection, repeat the above operation. Long press the wheel to exit.





3. Function Instruction





3.1 Menu Function

The main menu including Assist, Marker, Image, User, System 5 parts.







Assist

 Analysis	Off, On After turning on, waveform, , histogram and audio meters will be shown.
 Waveform	Off, On Type: RGB, YUV This essential feature assists with the calibration of professional video cameras. It shows the overall brightness of the image assisting the video professional in correcting exposure. The waveform feature also checks the evenness of the lighting when lighting a chromakey or background.
 Vectorscope	Off, On Shows how saturated the image is and where the pixels in the image land on the color spectrum.
 Histogram	Off, On Type: Y, RGB, Y+RGB

 Focus Assist	Off, On Focus Color: Red, Green, Blue, White Focus Level: 1~100
 Audio Meters	Off, On
 Check Field	Off, On Type: red, green, blue, white
 Zebra	Off, On Level: 1~100
 False Color	Off, On Type: Spectrum, ARRI









Marker

 Nine Grid	Off, On
 Safe Areas	Off, On Type: 70%, 80%, 90%, 16:9, 16:10, 4:3, 5:4, 1:1, 1.91:1, 4:5, 9:16: 1.85:1, 2.35:1 Line Color: Red, Green, Blue, White, Black, Yellow
 Crosshair	Off, On
 Cinema Guides	Off, On Type: 16:9, 16:10, 4:3, 1.85:1, 2.35:1, 2.41:1, 1.91:1, 5:4, 1:1.91 Line Color: Red, Green, Blue, White, Black, Yellow After the Marker Mat is turned on, the Marker Mat Alpha 0%~75% can be adjusted.





Image

 Scan Mode	Off, On Mode: Under Scan, Over Scan
 Aspect Ratio	Off, On Type: 16:9, 16:10, 4:3, 5:4, 1.85:1, 2.35:1, user Under the “user”, you can customize the Video Width (100% ~ 200%) , Video Height (100% ~ 200%)
 Anamorphic	Off, On Type: 1.25x, 1.33x, 1.5x, 1.8x, 2.0x, 2.0x mag
 Mirror	Off, On Auto (the image will automatically adjust), 180 Degrees, Flip H, FlipV .
 Zoom	Off, On Zoom Times: 1.0x ~ 5.0x
 Freeze	Off, On
 Pixel to Pixel	Off, On









User



 HDR	Off, On HLG2020、HLG709、HLG P3
 LUT	Off, On After copying the 3D LUT file to the micro SD card and inserting it into the micro SD card slot, click Import or rotate the wheel to import the 3D LUT file. (up to 50) Note: the chip should be faced up when inserting the SD card,

	<p>and press it after inserting to ensure that the SD card is fully inserted.</p> <p>LUT List: display built in SLOG2, SLOG3, LOGC, VLOG and the custom LUTs</p>
 Display	<p>Reset: Off, On</p> <p>Color Temp.: 5600K, 6500K, 9300K, User</p> <p>Backlight: 0~100</p> <p>Brightness: 0~100</p> <p>Contrast: 0~100</p> <p>Saturation: 0~100</p> <p>Under the “user”, the red, green, and blue values of the image can be adjusted (0~255)</p>





System

 Wheel	<p>Backlight, Volume</p> <p>After selecting the wheel option, you can click Backlight or Voice , or rotate the wheel to select one of the shortcut key to set it to the rotary wheel adjustment (when the menu is not displayed).</p>
 Input	<p>HDMI, SDI (with SDI interface version)</p>
 Output	<p>HDMI: 1080P, Follow In</p>
 Fan	<p>Low, Medium, High</p>
 Language	<p>English, 中文, Español, Français, Deutsch, 日本語, 한국어로, Русский</p>
 OSD	<p>OSD Time: always, 15s, 30s, 45s, 60s</p> <p>OSD Alpha: 0%~75%</p>

 Volume	Mute: Off, On Volume: 0~100
 Reset	Off, On After confirmed, all the parameters will restore factory
 Upgrade	Current Version: show the current version of device Update After copying the update file to the SD card and inserting it into the micro SD card slot, you can click Update or rotate the wheel to update. Note: the chip should be faced up when inserting the SD card, and press it after inserting to ensure that the SD card is fully inserted.

3.2 Shortcut Menu

The user can call up the shortcut menu by swipe up from the bottom of the screen, and click on the corresponding menu box to open or set the corresponding function.

Click  the hide icon to close detailed parameters, and click  icon to display detailed parameters.

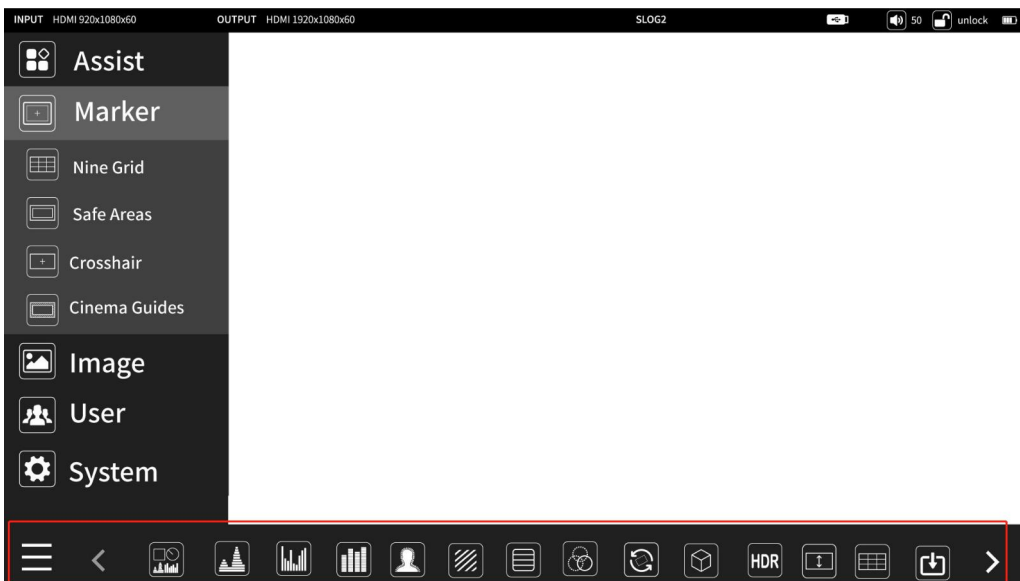

3.3 Status column

The top of the interface is the status column, the user can check the input and output resolution, battery level, etc.

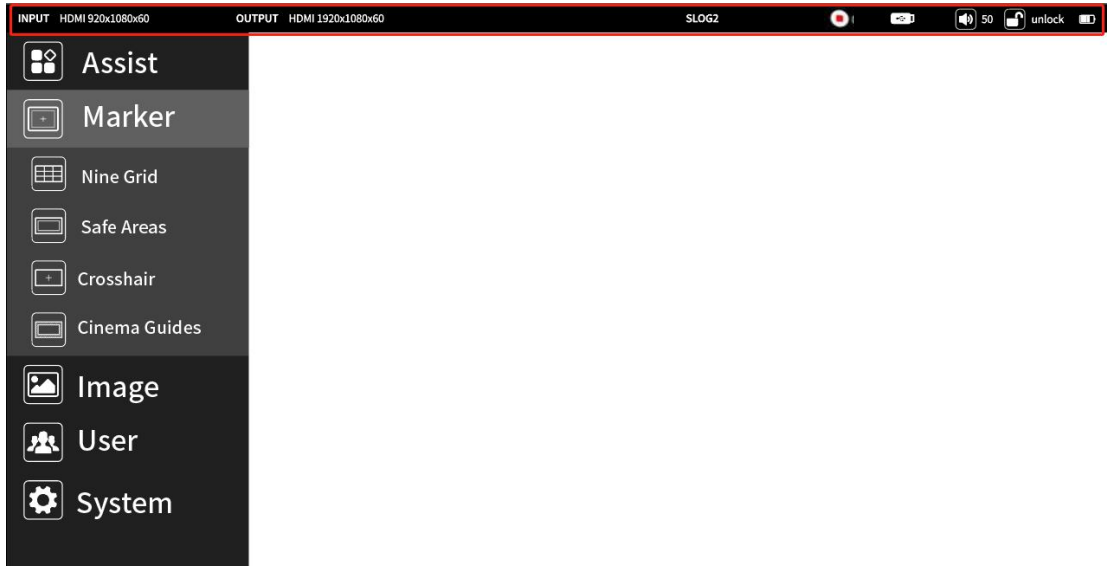

INPUT: display the resolution of INPUT resolution,e.g.: INPUT HDMI 1920x1080x60

OUTPUT: display the resolution of OUTPUT resolution, e.g.:OUTPUT HDMI 1920x1080x60

LUT: LUT status, when use LUT it will display the LUT name, such as SLOG2; without LUT, display LUT monitoring, e.g.: LUT Monitor

 : Recording Key, plug USB flash disk via USB2.0 port (supports FAT32 format), the top of screen will show the red recording key, just click it to start record, and will display the recording time, when the recording is about 1 minute, the information displayed on the top screen will be hidden automatically. You can click anywhere on the screen to view the recording time or click the recording key again to end the record.

Volume: display the voice0~100

Lock: display the status of touch function。 Lock indicates the touch function locked, Unlock indicates support touch.

Battery Level: battery level status,when use battery power supply, according to four full bars to display the battery level. full-bar: 80%~100%;

three-bar: 50%~80%; two-bar: 30%~50%; one-bar: 10%~30%; empty: less than 10%, the color of battery icon change to red.

Note: The status bar is put away by default and is only displayed when the main menu or shortcut menu is turning on

4. Support Formats

SDI Support Format (SDI version)	480i 576i 1080i@59.94/60 720p@23.98/24/25/29.97/30/50/59.94/60 1080p@23.98/24/25/29.97/30/50/59.94/60 1080psf@23.8/24/25/29.7/30
HDMI 2.0 Support Format	SMPTE 720p@50/60 1080i@50/60 1080p@24/30/50/60 720p (60/59.94/50/30/29.97/25/24/23.98) VESA 1024×768@60 1280×720@60 1280×768@60 1280×800@60 1280×1024@60 1360×768@60 1366×768@60 1440×900@60 1600×1200@60 1680×1050@60 1920×1080@60 1920×1200@60 3840×2160@60 4096×2160@60
HDMI 1.4 Support Format	SMPTE 720p@50/60 1080p@24/25/30/50/60 VESA 1024×768@60 1280×720@50/60 1280×768@60 1280×1024@60 1360×768@60 1920×1080@24/25/30/50/60

5. Technical Parameters

Panel Size	6" touch screen
Resolution	1920 × 1080 pixels
Dot Pitch	0.069 (H) × 0.069 (V) (mm)
Aspect Ratio	16:9

Brightness	450cd/m ²
Contrast	1000:1
Viewing Angle	80°/80°(L/R) 80°/80°(U/D)
Backlight	LED
Input	SDI (optional), HDMI 2.0
Output	SDI (optional), HDMI 1.4, DC OUT 8.4V
Other Interface	USB2.0 (recording), Micro SD Card Slot
Record Format	MP4 (1920x1080 resolution)
Audio	3.5mm Stereo Headphone
Power Input Voltage	7~14V
Power Consumption	≦ 11W
Unit Size	152Lx86Hx23D (mm)
Unit Weight	230g
Mount Points	(3) ¼-20 thread points (top, bottom, right)
Working Temperature	-20°C ~ 50°C
Storage Temperature	-30°C ~ 60°C

6. Trouble Shooting

6.1 Only black and white or monochrome picture:

- ① please check saturation, brightness & contrast adjustment.
- ② Please check "Monochrome" is in black, white or monochrome image or other condition.

6.2 NO Image after put on the power

- ① Check if signal cable connecting is in good condition.
- ② Check signal cable connecting, and make sure to use the standard adapter to connect the monitor. If power is supplied by battery, please check if the battery is fully charged.

6.3 Earphone No sound

- ① Check if Volume control do not open, press the volume button, and try to increase the volume.

- If there are still other problems, please contact with our related technologists.
- ★ As we are improving product features and product performance, so if there is any change on the specification without prior notice.